

# Air Duct Heaters Types RDFF, RDIF, RDFT & RDIT

## Application

Ruffneck™ air duct heaters are for use in comfort heating applications. Typical applications include:

- make-up air heating
- air pre-heating
- air handling equipment
- fan coils
- terminal reheating
- multi-zone reheating
- heat pump auxiliary systems
- return air heating

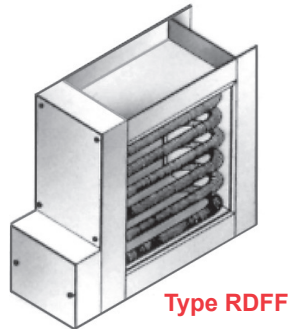

In Canada these units are marketed under the Caloritech™ brand name. Refer to Caloritech™ Catalogue Section C.

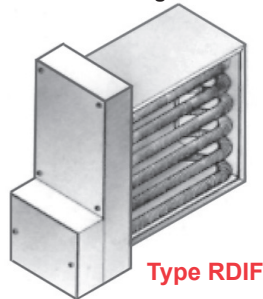

**Type RDFF** is a flanged duct heater with finned tubular heating elements.

**Type RDIF** is an insert duct heater with finned tubular heating elements.

**Type RDFT** is a flanged duct heater with incoloy® (nonfinned) tubular heating elements.

**Type RDIT** is an insert duct heater with tubular heating elements.

## Standard Features

- Primary linear cutout: 71°C (160°F) 277/600 VAC, 25/10 amp non-inductive
- Secondary linear cutout: Manual reset complete with back-up magnetic contactor on units under 300V, 30 kW and less, 107°C (225°F) 277/600 VAC, 25/10 amp non-inductive

## Optional Auxiliary Duct Heater Controls

These controls are available as factory installed on the duct heater or as an EEMAC rated (specify) control panel for wall mount:

- wall thermostats - T498A T6051A (1 stage) T6052A (2 stage) T921A (0 - 135 ohm)
- duct thermostats - T675A (1 stage) T678A (2 stage) T991A (0 - 135 ohm)
- bulb holders
- silent contactors
- SCR controllers
- sail switch
- differential pressure switch
- main disconnect
- pneumatic electric switches
- on-off switch
- magnetic contactors
- step controllers
- HRC fusing
- control transformers
- fan interlock relay
- pilot lights

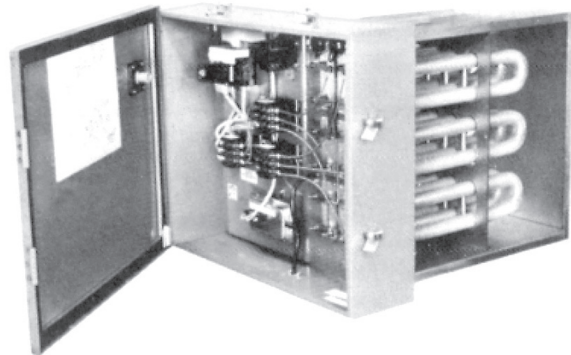

## Element Types

The finned tubular element design is the most popular. It incorporates the highest wattage per cross-sectional duct area, thus making it more economical than the incoloy® tubular design.

Fig. 1 - Finned Tubular Elements

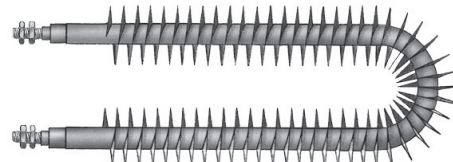

Finned tubular elements are constructed using a steel tube with a corrugated steel fin wrapped around it and brazed together. This increases the heat transfer surface of the element resulting in a lower operating temperature than tubular designs.

**RDFF, RDIF, RDFT & RDIT**

## Element Types (continued)

**Fig. 2 - Tubular Elements**

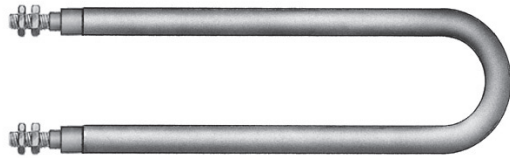

Incoloy® tubular elements are similarly constructed, but without the steel fin in order to increase the corrosion resistance.

The incoloy® design should be chosen where high humidity or slightly corrosive chemical contaminants are present in the air stream. These units are made and approved on special order only.

Both element types are designed to provide many years of maintenance free service.

Unlike open coil designs, duct heaters fitted with tubular elements are not subject to hazards of electrical shock which allows installation close to a register or grille.

## Recommended Kilowatts

In order to select the proper kW for your application, use Figure 3 below.

**Fig. 3 - Recommended Kilowatts**

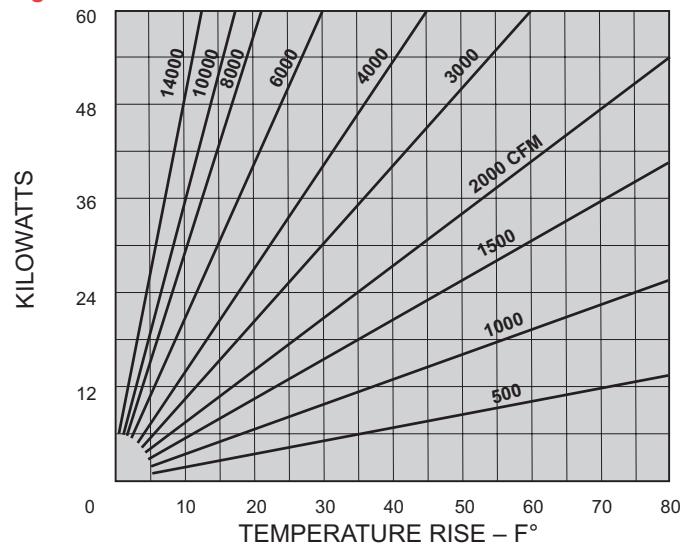

## Wiring and Auxiliary Controls

Ruffneck™ electric duct heaters are available for supply voltages up to 600V, 3 phase. Multi-staging to provide increments of temperature rise can be incorporated where dimensional space and element spacing allows. Special electrical features are available providing simple or sophisticated temperature control to suit individual requirements. See optional controls on previous page.

## Construction

Two basic heater frame constructions are available, flange type or insert type (see Figures 4 and 5 below).

**Fig. 4 - Insert Type**

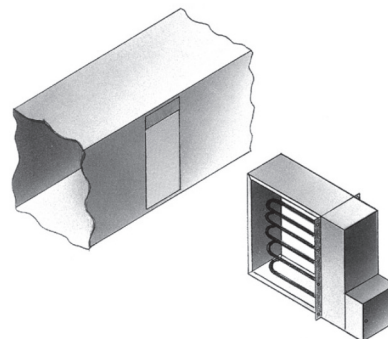

**Fig. 5 - Flange Type**

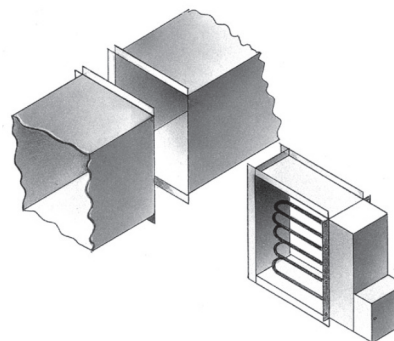

All frames are fabricated from 16-gauge satin-coat steel. Specially constructed stainless-steel frames are also available.

A unique modular construction using stock frame components is employed using vertical and horizontal dimensional increments of two inches, ensuring rapid delivery.

## RDFE, RDIF, RDFT & RDIT

## Air Duct Heaters (continued)

### Standard Dimensions

Insert type duct heaters are slightly undersized to permit installation in ducts having the A and B dimensions listed in Table 1.

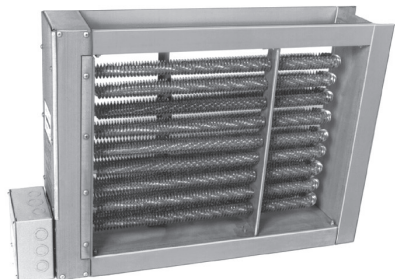

### Selection and Installation

Finned tubular duct heaters are approved for horizontal duct installation where the maximum inlet air temperature does not exceed 25°C (77°F) and the maximum rating does not exceed 120 kW.

Multiple heaters can be installed in tandem (series) provided that the inlet temperature to any heater section (one heater) is not more than 25°C (77°F) and the air velocity is not less than the requirements of Figure 6. Check factory if you require assistance.

**Fig. 6 - Air Velocity Requirements**

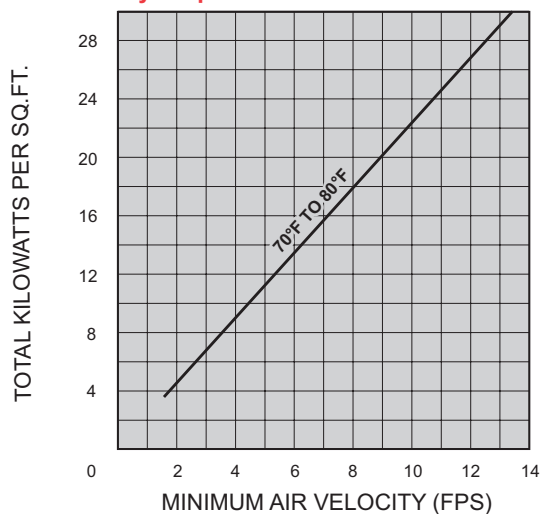

See Table 1 for typical duct heater sizes and kW ratings based on an air flow velocity of 500 ft/min or higher.

If the flow velocity is less than 500 ft/min, the typical maximum kW ratings in the table must be derated using Figure 7.

Multiply the kW ratings shown in Table 1 by the appropriate derating factor from Figure 7.

**Fig.7 - Derating Factors**

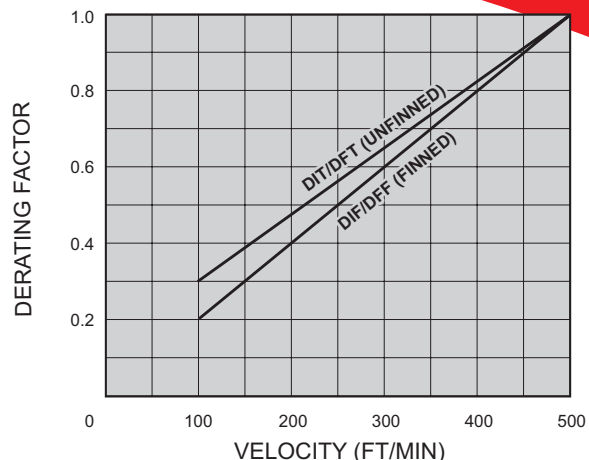

Table 1 below lists some of the more common heater sizes with maximum kilowatt ratings for each size. Stock modular frames allow quick delivery for other sizes in increments of 2" (51 mm).

**Table 1 - Maximum Single Heater kW Rating for Typical Duct Heater Sizes**

DIMENSIONS in. (mm) A x B	Types RDIF / RDFF		Types RDIT / RDFT	
	MAX. kW	MAX. No. OF ELEMS.	MAX. kW	MAX. No. OF ELEMS.
6 x 6 (125 x 152)	2.5	3	1.5	6
8 x 6 (203 x 152)	3	3	3.0	6
10 x 6 (254 x 152)	4	3	2.5	6
10 x 8 (254 x 203)	5.5	4	3.5	8
12 x 6 (305 x 125)	5	3	3.5	6
12 x 8 (305 x 203)	6.5	4	4.5	8
12 x 10 (305 x 254)	8	5	5.5	10
14 x 8 (356 x 203)	7.5	4	5.5	8
14 x 10 (356 x 254)	9.5	5	6.5	10
14 x 12 (356 x 305)	11.5	6	8.0	12
16 x 10 (406 x 254)	11	5	7.5	10
16 x 12 (406 x 305)	13	6	9.0	12
16 x 14 (406 x 356)	15.5	7	10.5	14
18 x 12 (457 x 305)	15	6	10.5	12
18 x 14 (457 x 356)	17.5	7	12	14
18 x 16 (457 x 406)	20	8	14	16
20 x 14 (508 x 356)	19	7	13.5	14
20 x 16 (508 x 406)	22	8	13.5	16
20 x 18 (508 x 457)	25	9	17.5	18
22 x 16 (559 x 406)	24	8	17	16
22 x 18 (406 x 457)	27.5	9	19	18
22 x 20 (406 x 508)	30.5	10	21	20
24 x 18 (610 x 457)	30	9	21	18
24 x 20 (610 x 508)	33	10	23	20
24 x 22 (610 x 559)	36.5	11	25.5	22
26 x 20 (660 x 508)	36	10	25	20
26 x 22 (660 x 406)	39.5	11	27.5	22
26 x 24 (660 x 610)	43	12	30	24
28 x 22 (711 x 559)	42.5	11	29.5	22
28 x 24 (711 x 610)	46.5	12	32.5	24
28 x 26 (711 x 660)	50.5	13	35	26
30 x 24 (762 x 610)	50	12	35	24
30 x 26 (762 x 660)	54	13	37.5	26
30 x 28 (762 x 711)	58	14	40.5	28
30 x 30 (762 x 762)	62.5	15	43.5	30

**RDFF, RDIF, RDFT & RDIT**