

The QuikKILN Oven

Electric Halogen
Short Wavelength
High Density

QuikKILN high-intensity ovens are representative of our ongoing commitment to product development, taking infrared into previously uncharted high-temperature and high-speed applications.

The Emitter:

- Halogen T-3 bulb

- Ceramic primary reflector applied to the rear half of the bulb to direct the bulk of the infrared energy to the work piece.

-
- Offered in a variety of wattages:

- 1600W, 2500W, in the SS series

- 2500W in the PYRO series

-
- 480V is standard

- Offered in a variety of voltages upon request



The QuikKILN Oven

The Heater Section:

- Assembled and tested in the DriQuik™ facility in Greensburg, Indiana.
- Engineered to maximize halogen T-3 bulb life
 - Bulb seal area temperature of 300°F (149°C)
 - Bulb sheath temperatures below 900°F (482°C)
- PYRO Series Heater
 - Heater face and interior are manufactured entirely of refractory material to minimize energy transfer to the heater fixture, oven structure, and to maintain infrared reflection/ re-radiation to the oven interior.
 - Pressure ventilated to extend bulb life.
 - Emitter assembly is mounted in a formed stainless steel housing.
 - Standard back-loading design for safe and convenient maintenance access.
 - Ideal curing solution for high temperature processes and/or very high-speed applications.
 - Product temperatures up to 1500°F (815°C).
- SS Series Heater
 - Lower infrared density design than the PYRO series. Pressure ventilation is not required to maintain maximum bulb life.
 - Emitter assembly is mounted in a formed stainless steel housing.
 - Curing solution for applications where the part temperature maximum limit is 800°F (427°C) or below.
 - Suited for high-speed applications.

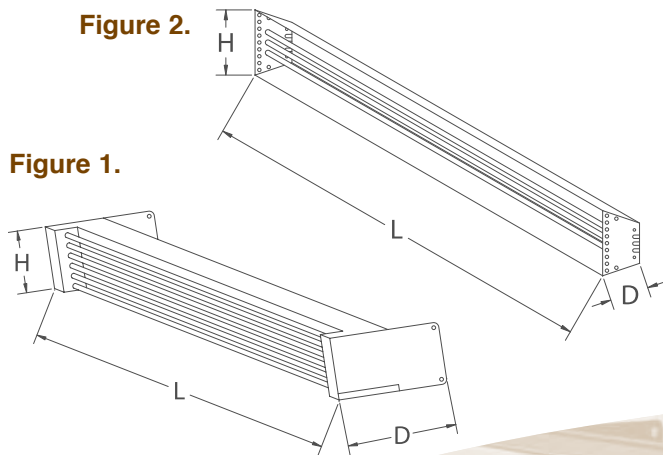

The Oven System:

- Custom configurations utilizing an array of standard modular heater sections profiled to the specific process and/or application.
- Standard features include powder coated U-channel type support frame, engineered exhaust collection and appropriate closure panels.
- PYRO series ovens interior lined with refractory material when the process temperature requires heat isolation from the emitter and oven structure.
- Insulated reflective stainless steel interior wall panels.
- Customized features available upon request or as the process dictates.
- Includes a user-friendly control package with all required components for safe and efficient operation of the oven system (see page 23 for complete explanation of the many QuikCOMMAND features).

The Uses and Benefits:

- Instantaneous thermal adjustment.
- Process times faster than other infrared technologies.
- Reduces dwell time, eliminating the heat sink problems experienced with convection ovens.
- Most effective on substrates requiring temperatures of 500°F (260° C) and above, though capable of curing standard lower temperature applications at a high rate of speed.

The Heater Specifications:

Heater Part Number	Series	Input (kW)	Size in Inches			Fig. No.
			H	L	D	
DQ6-2500T3(6)	PYRO	15	6	30	6	1
DQ6-2500T3(3)	PYRO	7.5	6	30	6	1
DQ3SS-2500T3(3)	SS	7.5	5	30	3	2
DQ3SS-2500T3(2)	SS	5	5	30	3	2
DQ3SS-2500T3(1)	SS	2.5	5	30	3	2
DQ3SS-1600T3(3)	SS	4.8	5	20	3	2
DQ3SS-1600T3(2)	SS	3.2	5	20	3	2
DQ3SS-1600T3(1)	SS	1.6	5	20	3	2

Note: 480V is standard; other voltages available upon request
Pyro series emitters include rear side collar for forced-air cooling.