

# The QuikCOIL Oven

Electric Tubular Element  
Medium Wavelength

The QuikCOIL oven has become a popular upgrade to our traditional product offerings. Its durability and versatility have entrusted this heater to numerous coating manufacturers for use in many applications across several markets.

## The Emitter:

- This unique incoloy sheathed tubular element, with a nickel chromium resistance coil packed in magnesium oxide, has been engineered with exact watt density specifications to assure consistent temperatures and optimum transfer efficiencies of the radiant heat from source to substrate.

---

- Manufactured in our Caloritech™ facility in Orillia, Ontario under an internationally recognized ISO-9001:2000 quality management system.

- 
- Offered in a variety of wattages:
    - 750W, 1000W in the #2 and #4 series
    - 1500W, 2000W in the BR series

---

  - Offered in a variety of voltages (for convenient series wiring):
    - 208V for 208-volt system
    - 240V for 240-volt and 480-volt systems (one or two in series)
    - 300V for 600-volt system (two in series)

---

  - Emitter temperatures to 1500°F, within the medium wavelength range.



The QuikCOIL Oven

14 Medium Wavelength

## The Heater Section:

- Each emitter is mounted within an independent polished stainless steel parabolic reflector, enabling a superior uniform heat pattern.
- Offered in two reflector sizes:
  - 10.5-inch by 10.5-inch (#2 and #4 series)
  - 15-inch by 15-inch (BR series)
- Modular industrial heater sections comprised of multiple emitters, either two or four per section.
- Reflector and emitter assembly mounted within a formed steel housing, which is finished in a durable textured polyester powder coat.
  - #2 series, 10 1/2-inch by 21-inch, contains two emitters
  - #4 series, 10 1/2-inch by 42-inch, contains four emitters
  - BR30, 15-inch by 30-inch, contains two emitters
  - BR60, 15-inch by 60-inch, contains four emitters
- Standard back-loading design for safe and convenient maintenance access (front-loading configuration available upon request).

## The Heater Specifications:

Heater Part Number	Series	Input (kW)	Size in Inches			Fig. No.
			H	L	D	
#2-750QC	#2	1.5	10 1/2	21	5 1/2	1
#2-1000QC	#2	2.0	10 1/2	21	5 1/2	1
#4-750QC	#4	3.0	10 1/2	42	5 1/2	2
#4-1000QC	#4	4.0	10 1/2	42	5 1/2	2
BR30-1500QC	BR	3.0	15	30	6 1/2	1
BR30-2000QC	BR	4.0	15	30	6 1/2	1
BR60-1500QC	BR	6.0	15	60	6 1/2	2
BR60-2000QC	BR	8.0	15	60	6 1/2	2

Note: 208V, 240V, 480V and 600V are the standard available voltages.

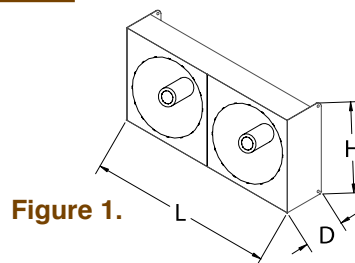

Figure 1.

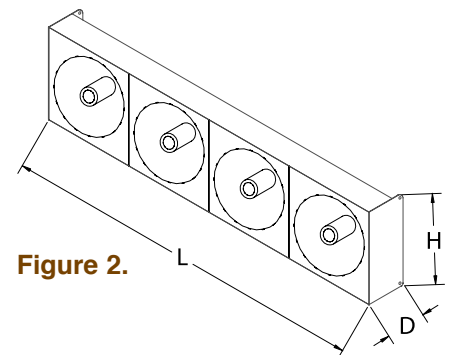

Figure 2.

## The Oven System:

- Custom configurations utilizing an array of standard modular heater sections profiled to the specific process and/or application.
- Standard features include powder coated U-channel type support frame, engineered exhaust collection and appropriate closure panels.
- Customized features available upon request or as the process dictates.
- Includes a user-friendly control package with all required components for safe and efficient operation of the oven system (see page 23 for complete explanation of the many QuikCOMMAND features).

## The Uses and Benefits:

- The variety of available emitter wattages and standard heater sizes allows the QuikCOIL oven package to be one of the more versatile, yet affordable, in the DriQuik™ product line.
- The even heat patterning produced through the coil-shaped emitter and parabolic reflector makes the QuikCOIL oven system popular on substrates with complex geometric part profiles.
- The modular design and sturdy emitter allows the QuikCOIL heaters to be configured in virtually any pattern throughout numerous processes.
- Most effective in applications requiring surface temperatures in the 250°F to 450°F range, such as in high solids or powder coat finish systems.
- When production rates increase or finishes change, the QuikCOIL oven is often the preferred choice as a booster system to existing convection ovens, as they provide a quick and even temperature rise in minimal plant space at an affordable cost.