

HOLES TO BE DRILLED ON SITE AS
REQ'D FOR HARNESS ATTACHMENT

NOTES:

- 1) MATERIAL: ASTM A36 FL 3/16" x 1 1/4"
HOT ROLLED MILD STEEL; ZINC PLATED.
- 2) ALL DIMENSIONS IN INCHES, UNLESS OTHERWISE SPECIFIED.

REV.	REVISION DESCRIPTION				DATE	BY
TITLE: Wall Bracket-24" Mounting Bracket-SZP						
DWG NO.: 01-04-0008		SHEET: 2 OF 2		TOLERANCE UNLESS NOTED OTHERWISE		
SYTLINE NO.: WBRK-24		± 1/2°	± 0.005"	± 1/16"	± mm	
SCALE: AS SHOWN		ANGULAR	DECIMAL	FRACTIONAL	METRIC	
DRN BY: D. AMYOTTE		19 Mar 2004		 CCI Thermal Technologies Inc. EDMONTON, ALBERTA		
CHK'D BY: NJS						
APP'D. BY: MAN						

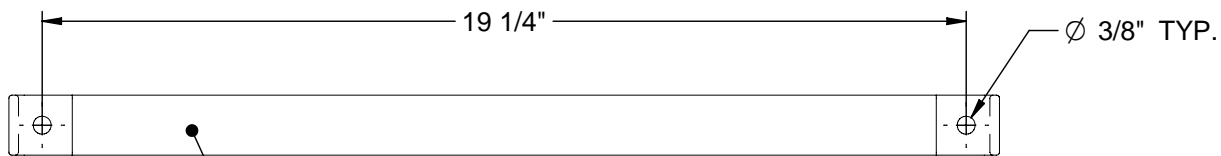
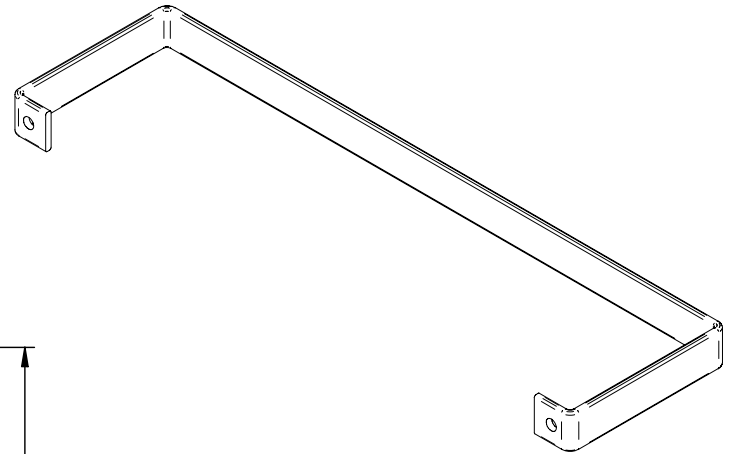
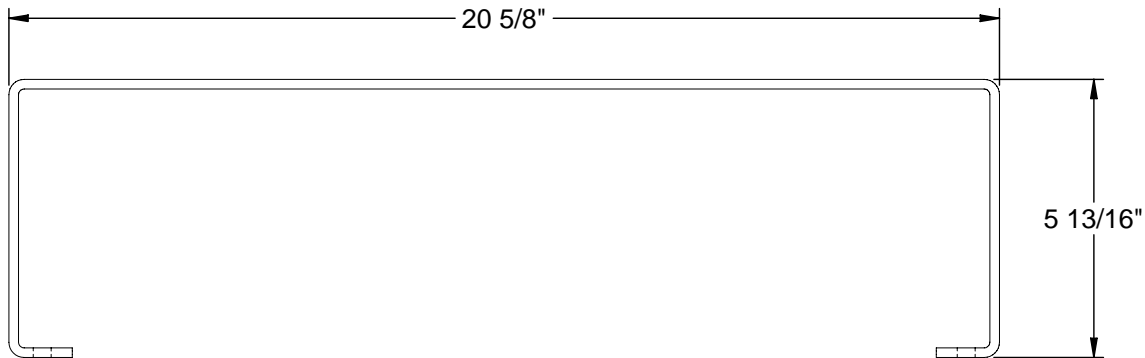

HOLES TO BE DRILLED ON SITE AS PER
REQUIRED FOR HARNESS ATTACHMENT

NOTES:

- 1) MATERIAL: ASTM A36 1 1/4" x 3/16" HOT ROLLED MILD STEEL; ZINC PLATED
- 2) ALL DIMENSIONS IN INCHES.

REV.	REVISION DESCRIPTION	DATE	BY
TITLE: Wall Bracket-18" Mounting Bracket-SZP			
DWG NO.: 01-04-0006 SHEET: 2 OF 2		TOLERANCE UNLESS NOTED OTHERWISE	
SYTLINE NO.: WBRK-18		± 1/2° ANGULAR	± 0.005" DECIMAL
SCALE: AS SHOWN		± 1/16" FRACTIONAL	± mm METRIC
DRN BY: D. AMYOTTE		19 Mar 2004	
CHK'D BY: NJS			
APP'D. BY: MAN			



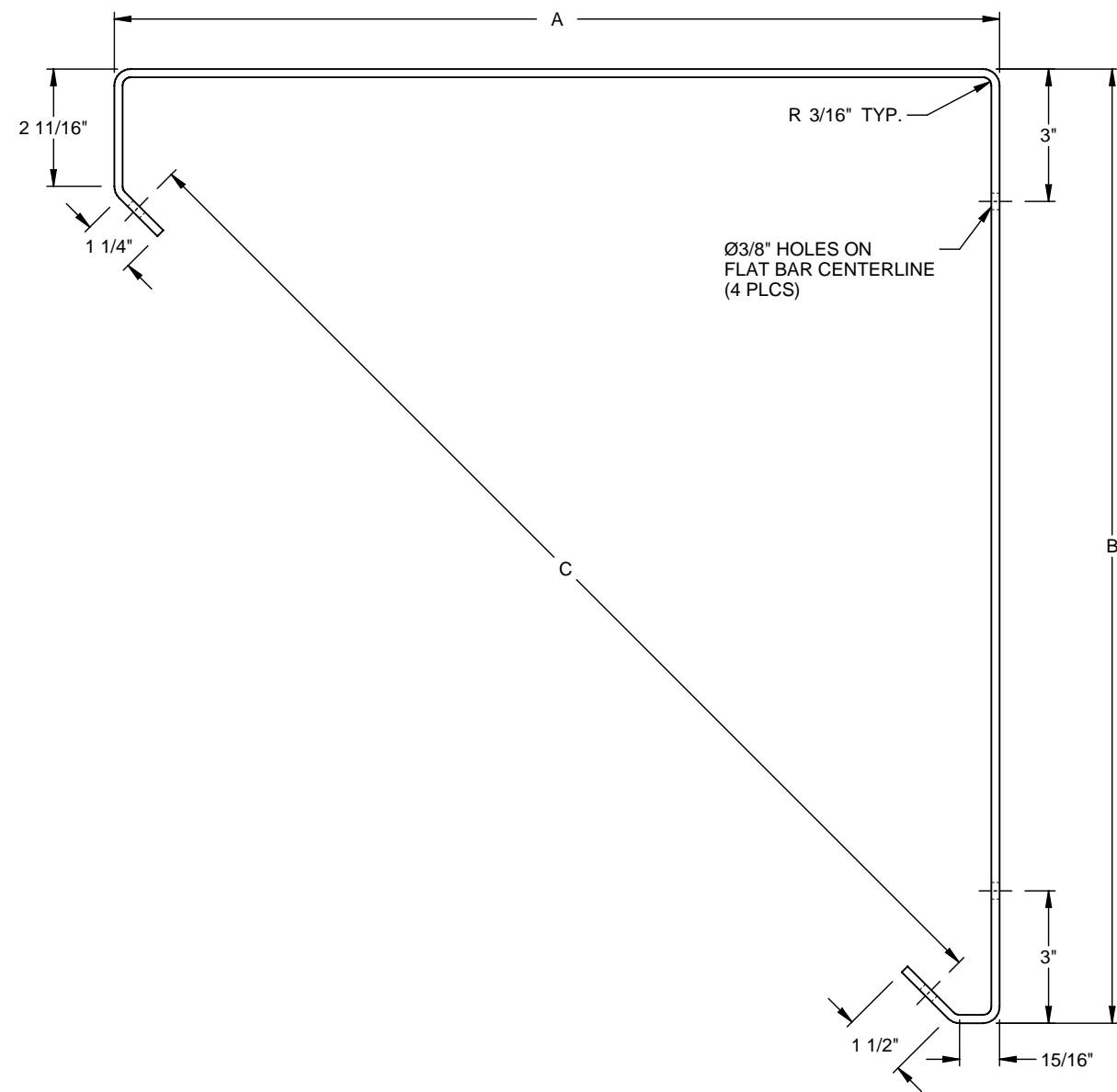

BENDING DETAILS
1:4

NOTES:

- 1) MATERIAL: 1 1/4" x 3/16" HOT ROLLED MILD STEEL, A36
- 2) ALL DIMENSIONS IN INCHES, UNLESS OTHERWISE SPECIFIED.

18x24	20 1/16	21 5/8	25 1/4	FL-WBRK-24-45
18x36	15 13/16	17 3/8	19 1/4	FL-WBRK-18-45
18x48	15 13/16	17 3/8	19 1/4	FL-WBRK-18-45
18x60	15 13/16	17 3/8	19 1/4	FL-WBRK-18-45
18x72	15 13/16	17 3/8	19 1/4	FL-WBRK-18-45
24x24	20 1/16	21 5/8	25 1/4	FL-WBRK-24-45
24x30	20 1/16	21 5/8	25 1/4	FL-WBRK-24-45
24x36	20 1/16	21 5/8	25 1/4	FL-WBRK-24-45
24x48	20 1/16	21 5/8	25 1/4	FL-WBRK-24-45
24x60	20 1/16	21 5/8	25 1/4	FL-WBRK-24-45
24x72	20 1/16	21 5/8	25 1/4	FL-WBRK-24-45
HEATER MODEL	A	B	C	BRACKET PART NO.
DIMENSIONS				

REV.	REVISION DESCRIPTION	DATE	BY
TITLE: BRACKET, 45° U-SHAPED VARIOUS SIZES			
DWG NO.: 01-04-0066 SHEET: 1 OF 2		TOLERANCE UNLESS NOTED OTHERWISE	
SYTLINE NO.: SEE TABLE		± 1/2° ANGULAR	± 0.030" DECIMAL
SCALE: AS SHOWN		± 1/16" FRACTIONAL	± 1 mm METRIC
DRN BY: nsanchez		12 Oct 2005	
CHK'D BY:			
APPD. BY:			
		 CCI Thermal Technologies Inc. EDMONTON, ALBERTA	