

## Pilot Gas Heater

### Engineered. Certified. Proven.

The Caloritech<sup>TM</sup> Pilot Gas Heater is specifically designed to heat the pilot tube gas stream of an automatic pressure reducing valve. A large pressure reduction through the pressure reducing valve will create a temperature drop due to the Joule-Thomson effect. This temperature drop can cause moisture in the gas stream to accumulate and damage the internal seals in the valve.

The Pilot Gas Heater combines a high efficiency aluminum casting with a digital temperature controller to maintain the pilot tube gas stream temperature regardless of the gas flow rate. The precise temperature control of this heater prevents damage to valve seals caused by freezing of entrained moisture while maintaining a temperature low enough to prevent damage by overheating.

### Features

- Digital indicating display of operating temperature and setpoint
- Hazardous locations ratings: CSA C/US certified for Class I, Div.1&2, Groups A,B,C,D; Class II, Div.1&2, Groups E,F,G; Class III, Div.1&2, Zones I&2, Groups IIA, IIB, IIC; Temperature Code T4
- Electronic controller for precise temperature control
- Internally adjustable temperature setting
- No maintenance required
- Impact resistant tempered glass
- Compact size - see back for dimensions
- Caloritech<sup>TM</sup> x-Max<sup>®</sup> anodized aluminum enclosure
- Multiple conduit entries
- 304SS heavy wall coiled tube
- Aluminum casting for efficient heat transfer
- 1500 PSIG operating pressure
- Replaceable heating element
- High limit protection
- 3/8" NPT inlet and outlet connections



CCI Thermal Technologies Inc.  
2721 Plymouth Drive  
Oakville, Ontario L6H 5R5  
1-800-410-3131  
www.ccithermal.com

## Pilot Gas Heater

Table 1 - Standard Heater Listing

Part #	Volts	Ph.	Wattage
PGH02511	120	1	250
PGH02521	208	1	250
PGH02531	240	1	250
PGH03511	120	1	350
PGH03521	208	1	350
PGH03531	240	1	350
PGH05011	120	1	500
PGH05021	208	1	500
PGH05031	240	1	500



Unit Weight: 17.5 lbs. (8.0 kg)

Figure 1 - Heater Dimensions

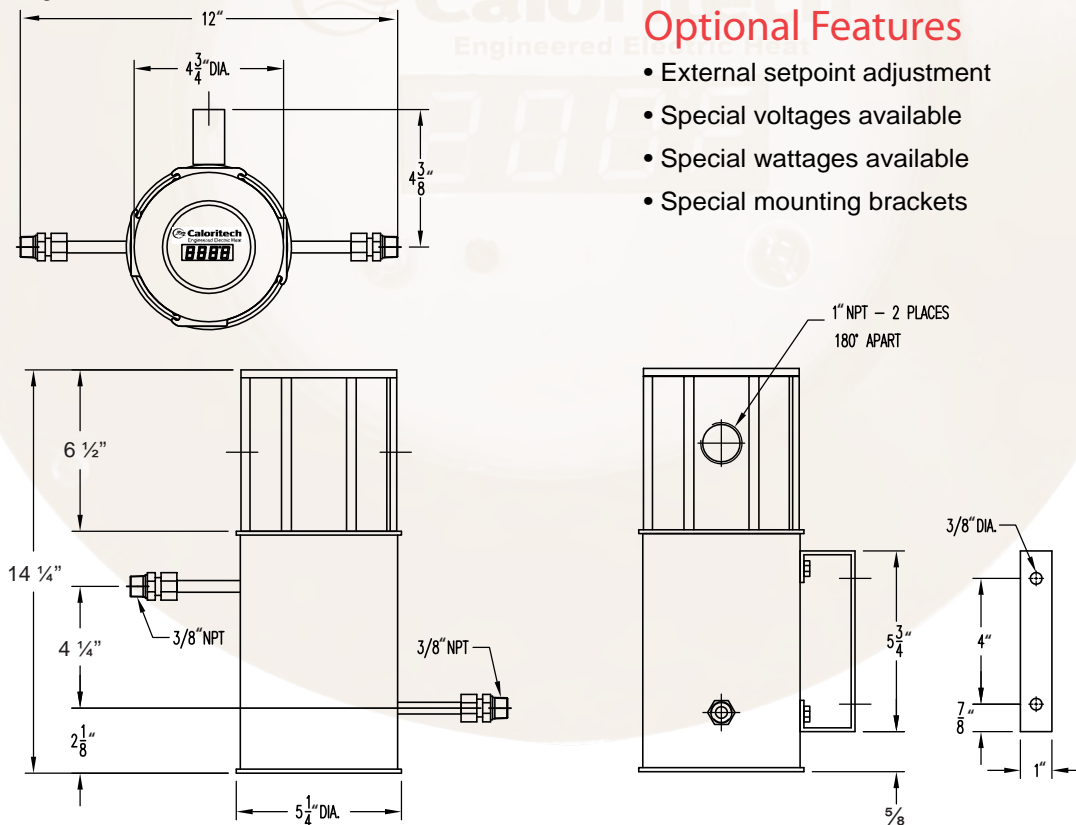

### Optional Features

- External setpoint adjustment
- Special voltages available
- Special wattages available
- Special mounting brackets

Edmonton  
5918 Roper Road  
Edmonton, AB T6B 3E1  
Canada

Phone 780-466-3178  
Fax: 780-468-5904  
Toll Free: 1-800-661-8529

Oakville  
2721 Plymouth Drive  
Oakville, ON L6H 5R5  
Canada

Phone 905-829-4422  
Fax: 905-829-4430  
Toll Free: 1-800-410-3131

Orillia  
1 Hunter Valley Road  
Orillia, ON L3V 6H2  
Canada

Phone 705-325-3473  
Fax: 705-325-2106  
Toll Free: 1-877-325-3473

Greensburg  
1420 West Main Street  
Greensburg, IN 47240  
USA

Phone 812-663-4141  
Fax: 812-663-4202  
Toll Free: 1-800-473-2402