

INSTALLATION, OPERATION AND MAINTENANCE INSTRUCTIONS FOR TYPE XDF – EXPLOSION PROOF DUCT HEATER



1.0 SCOPE

This manual details the installation, operation, and maintenance instructions for Caloritech™ type XDF explosion-proof duct heaters. Refer to Section 10 for specific drawings and bills of materials for related equipment supplied under this order.

Your XDF explosion-proof duct heater has been CSA C/US Certified to meet the requirements for hazardous location equipment for use in Canada and the United States. When properly maintained and serviced, you can expect years of trouble free operation.

Carefully read and follow all instructions outlined in this manual to ensure proper installation and safe operation of your heater.

2.0 GENERAL INFORMATION

2.1 DESCRIPTION

Caloritech™ type XDF explosion-proof duct heaters are designed for heating air or gases that contain potentially explosive substances. XDF heaters feature the unique Caloritech™ approach to explosion-proof electric heater design, which embodies safety and reliability.

The XDF is a factory pre-wired explosion-proof duct heater. Standard models are available in three duct sizes, with either a single or double bank of heating modules. XDF heaters are available as standard units with T3B, T3A, or T2D hazardous area temperature codes.

2.2 APPLICATION

The XDF is designed specifically for heating industrial spaces where potentially explosive substances are or may be present. Typical hazardous location environments include:

- Water and sewage treatment plants
- Oil refineries
- Pulp and paper mills
- Petrochemical plants
- Grain elevators
- Paint storage booths
- Cement plants

2.3 CONSTRUCTION

The XDF explosion-proof duct heater features heavy-walled carbon steel finned tubular heating elements with electroless nickel plated finish to provide safe, efficient, low temperature heat transfer. Standard units have a painted carbon steel duct section with mounting holes provided for attachment to the duct section.

XDF heaters feature the unique Caloritech™ patented x-Max® copper-free aluminum extruded terminal housing. A track-and-trolley system and threaded covers on each end allow easy access to wiring terminal connections.

Units are suitable for mounting in a horizontal duct section only.

2.4 STANDARD PRODUCT FEATURES

- T2D, T3A, or T3B temperature code
- CSA C/US Certified for use in hazardous areas. T2D units Certified for use in Class I, Division 1 & 2, Group C & D hazardous areas. T3A units Certified for use in Class I, Division 1 & 2, Group C & D; Class II, Division 1 & 2, Group E & F hazardous areas. T3B units Certified for use in Class I, Division 1 & 2, Group C & D; Class II, Division 1 & 2, Group E, F, & G hazardous areas.
- Painted steel duct section
- Differential pressure switch (supplied loose)
- Factory installed high limit sensing thermocouple(s)

2.5 OPTIONAL PRODUCT FEATURES

- Transition sections
- Stainless steel duct section
- Special temperature code
- Outlet air thermostat
- Outlet air thermocouple

3.0 SPECIAL NOTICES

The following special notices highlight important information in the installation and maintenance sections. Each serves a special purpose, and is displayed in the format shown:



This symbol indicates a potentially hazardous situation, which, if not avoided, can result in personal injury or damage to the equipment.



This symbol indicates a potentially hazardous situation, which, if not avoided, may be a shock hazard.



This symbol indicates an imminently hazardous situation, which, if not avoided, could result in death or serious injury.

4.0 PRE-INSTALLATION

4.1 Inspect the heater for possible damage due to shipping and handling. Claims for shipping damages shall be placed with the carrier.

4.2 Check the heater nameplates to ensure that the heater area classification and temperature code are suitable for the hazardous area classification.

4.3 Verify that the nameplate voltage, phase, and wattage are as ordered and are the same as the electrical power supply available.



DO NOT CONNECT THE HEATER TO AN ELECTRICAL SUPPLY VOLTAGE OTHER THAN THAT SHOWN ON THE PRODUCT NAMEPLATE.



REVIEW THIS MANUAL AND ALL DRAWINGS CONTAINED WITHIN PRIOR TO INSTALLATION, WIRING, OR OPERATION OF THE HEATER.

5.0 DIMENSIONS AND INSTALLATION

The heater must be installed by qualified personnel in strict compliance with the electrical code and hazardous locations standards.



THE HEATER MUST BE INSTALLED IN A HORIZONTAL DUCT SECTION ONLY. IMPROPER ORIENTATION OF THE HEATER COULD AFFECT THE SAFE AND RELIABLE OPERATION OF THE HEATER.

5.1 HEATER DIMENSIONS

Table 1 - Heater Dimensions and Weights (See Fig. 1)

Duct Size (W x H)	No. of Banks	Dimensions					Weight kg (lbs)
		A	B	C	D	L	
610 x 305 (24 x 12)	1	610	305	686	381	927	41 (90)
	2	(24)	(12)	(27)	(15)	(36½)	73 (160)
762 x 457 (30 x 18)	1	762	457	838	533	1080	61 (135)
	2	(30)	(18)	(33)	(21)	(42½)	114 (250)
914 x 610 (36 x 24)	1	914	610	991	686	1232	82 (180)
	2	(36)	(24)	(39)	(27)	(48½)	148 (325)

Note: All dimension in millimeters (inches in brackets).

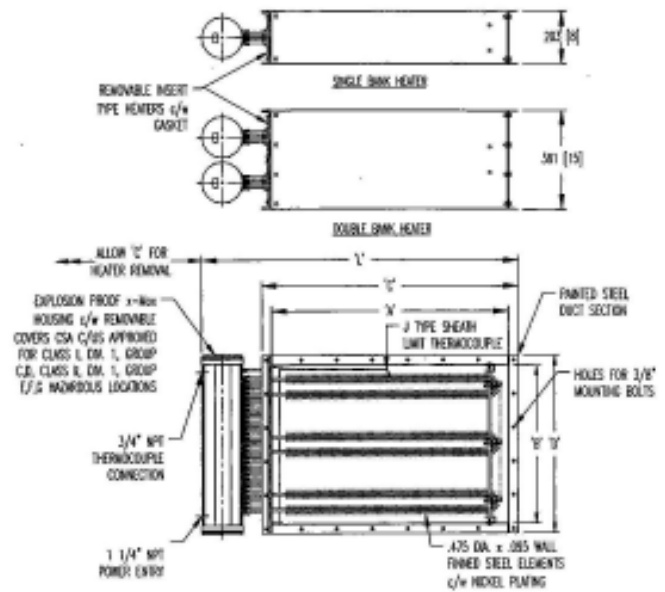

Figure 1 - XDF Heater Dimensions

5.2 INSTALLATION

5.2.1 The heater is designed for installation in a horizontal duct with the terminal boxes at the side. Improper orientation of the duct heater could effect the safe and reliable operation of the heater.



IMPROPER ORIENTATION OF THE HEATER COULD AFFECT THE SAFE AND RELIABLE OPERATION OF THE HEATER.



NEVER USE THE CONTROL HOUSINGS FOR LIFTING OR MOVING THE HEATER AS THIS COULD DAMAGE THE HEATING ELEMENTS AND CONDUIT.

5.2.2 To install the heater, bolt the heater assembly into the customer supplied ducting system. If necessary, reinforce with duct supports to support the heater weight as shown in Table 1. Note proper orientation of heater, as shown by the "TOP" and "AIRFLOW" labels.

5.2.3 An explosion-proof pressure differential switch has been supplied loose. Install the switch in a suitable location and with proper orientation. Install tubing between the switch and the duct using the appropriate port on the switch body (sensing high or low pressure). Consult manufacturer's operation instructions included with this manual.



THE PRESSURE DIFFERENTIAL SWITCH IS A CRITICAL SAFETY COMPONENT. IMPROPER INSTALLATION OF THE SWITCH MAY RESULT IN HAZARDOUS CONDITIONS.

6.0 WIRING



Whenever hazardous materials are present, ensure that the terminal housing covers, plugs, etc., are secured (but not over-tightened) before energizing the heater.



All circuits must be in the open position before removing junction or terminal box covers.



Use supply wires suitable for 90°C. Supply wires are to be fused with appropriately sized HRC fusing.



Use approved conduit and conduit seals as required by hazardous location standards.



Ensure that no power is connected to the equipment prior to making any connections.

6.1 The heater is factory prewired to supply terminal blocks in the heater terminal housing ready for direct connection to the power supply. The heater also contains one (1) high limit thermocouple per heating bank that must be wired to the control equipment.



For double bank heaters, Heater Bank #1 is defined as the inlet bank and Heater Bank #2 is defined as the outlet bank. This distinction is important in order to ensure proper high limit set limit set points must be set in the field. Table 2 gives the maximum high limit set points for safe operation of the heater. For initial start-up, set the high limit controllers to the values indicated in Table 2.

6.2 To wire the heater to the control equipment, make the following connections at the connection points indicated on the assembly drawing:

- a) 1¼" NPT conduit entries have been provided in each heater terminal housing for wiring the power supply and ground to the heaters. Connect the heating bank(s) to the contactor(s) in the control panel.
- b) ¾" NPT conduit entries have been provided on each heater bank for wiring the J type high limit thermocouple(s) to Certified, manual-reset high limit controller(s) in the control panel. Using appropriate thermocouple extension wire, connect the thermocouple(s) to the high limit controllers, ensuring proper connection of the positive and negative leads.
- c) Connect the "Normally Open" contacts of the supplied pressure differential switch to the interlocks in the control circuit.



After all connections have been made and before starting up the system, ensure that all housings, plugs, covers, etc. have been installed.

7.0 STARTUP AND OPERATION



TO ENSURE SAFE AND RELIABLE OPERATION, DO NOT EXCEED THE MAXIMUM OUTLET TEMPERATURE OF 40°C AND DO NOT ALLOW THE AIRFLOW TO DROP BELOW THE MINIMUM AIRFLOW AS SHOWN ON THE PRODUCT NAMEPLATE.

7.1 Turn on the airflow through the duct heater. Ensure that the minimum airflow, as shown on the product nameplate, is maintained at all times.

7.2 The field installed explosion-proof differential pressure switch may require field adjustment. Consult manufacturer's operation instructions included with this manual.



THE PRESSURE DIFFERENTIAL SWITCH IS A CRITICAL SAFETY COMPONENT. IMPROPER SETTING OF THE SWITCH MAY RESULT IN HAZARDOUS CONDITIONS.

7.3 Apply power to the control panel.

7.4 Turn the control on/off switch to "On".

7.5 Set the temperature controller to the desired set point. Do not exceed the maximum outlet temperature of 40°C.

7.6 Ensure that the temperature controller is working properly. Consult the manufacturer's operation instructions supplied with the temperature controller.

7.7 Except when purchasing a control panel to accompany your XDF heater, the high limit set points must be set in the field. Table 2 gives the maximum high limit set points for safe operation of the heater. For initial start-up, set the high limit controllers to the values indicated in Table 2.



TO PREVENT UNSAFE OPERATION OF THE HEATER, DO NOT EXCEED THE MAXIMUM HIGH-LIMIT SET POINTS. OPERATION OF THE HEATER WITH HIGH LIMIT SET POINTS GREATER THAN THOSE SHOWN IN TABLE 2 CREATES A SIGNIFICANT RISK OF EXPLOSION.

Table 2 - Maximum High Limit Set Points

Temperature Code	High Limit Set-Point (°C)		
	T2D	T3A	T3B
Heater Bank #1 (Inlet)	94	78	65
Heater Bank #2 (Outlet)	125	100	83

8.0 OVERHEAT PROTECTION

8.1 The heater is equipped one (1) high limit thermocouple per heating bank to sense the heating element sheath temperature. Each high limit thermocouple must be wired to a separate Certified, **manual-reset** high limit controller in the control panel. The set point of the controller(s) must not exceed the values given in Table 2.

8.2 In the event of fan failure, excessive dust buildup, or restricted airflow, the heater temperature may rise, causing the limit controls to open and break the power supply to the heater.



CYCLING OF THE HEATER ON THE HIGH LIMITS SHOULD NOT BE PERMITTED. Should this occur, the system should be inspected to determine the cause of the cycling, and the condition must be corrected before regular operation is resumed.

9.0 MAINTENANCE



DISCONNECT ALL POWER TO THE EQUIPMENT PRIOR TO SERVICING.

9.1 Periodically inspect the heater installation to ensure that all connections, fitting, plugs, screws, covers, etc. are tight and free of corrosion.

9.2 Check the surface of the duct section and terminal boxes for dust and debris, especially after seasonal shutdowns. Clean with a blast of air or vacuum.

9.3 Check the surface of the finned elements for dust and debris. Clean with a blast of air.

9.4 Ensure that all fuses are in proper working order.

9.5 Maintain the pressure differential switch in accordance with the manufacturer's instructions.

9.6 Field repair of the heater should not be undertaken. In the event that the heater must be repaired, contact the factory.

10.0 DRAWINGS AND LITERATURE

10.1 LITERATURE

The following manufacturer's literature has been included with this manual:

a) Explosion-Proof Pressure Differential Switch

11.0 FIELD SERVICABILITY

The XDF explosion-proof duct heater is not field-serviceable. If your heater requires servicing, please consult the factory.

WARRANTY

CCI Thermal Technologies Inc. warrants to the purchaser of each new product that any part thereof which proves to be defective in material or workmanship under normal use within 24 months of the date of shipment or 12 months from the date of start of operation (whichever occurs first) will be repaired or replaced without charge. Any such defect should be brought to the attention of the company's office from which the product was purchased, which is authorized to furnish or replacement within the terms of this warranty.

The Company will not be responsible for any expenses incurred in installation, removal from service, transportation cost, or damages of any type whatsoever, including incidental or consequential damages. Some states or provinces do not allow exclusion or limitation of incidental or consequential damages so the preceding exclusion or limitation may not be applicable to you.

Since we cannot anticipate or control the condition under which our products may be used, we accept no responsibility for the safety and suitability of our products when used alone or in combination with other products. Tests for safety and suitability of the products should be done by the user.

This warranty will not apply if, in the judgment of the Company damage or failure has resulted from accident, alteration, misuse, abuse or operation on an incorrect power supply. The foregoing is in lieu of other warranties expressed or implied. CCI Thermal Technologies Inc. neither assumes nor authorizes any person to assume for it any other obligation, during transportation, installation and operation or liability in connection with the said product.

Since the paint finish may be damaged during installation and operation, no warranty applies to such paint finish except for manufacturing defects.

Heaters are not guaranteed against damage caused by corrosion.

