

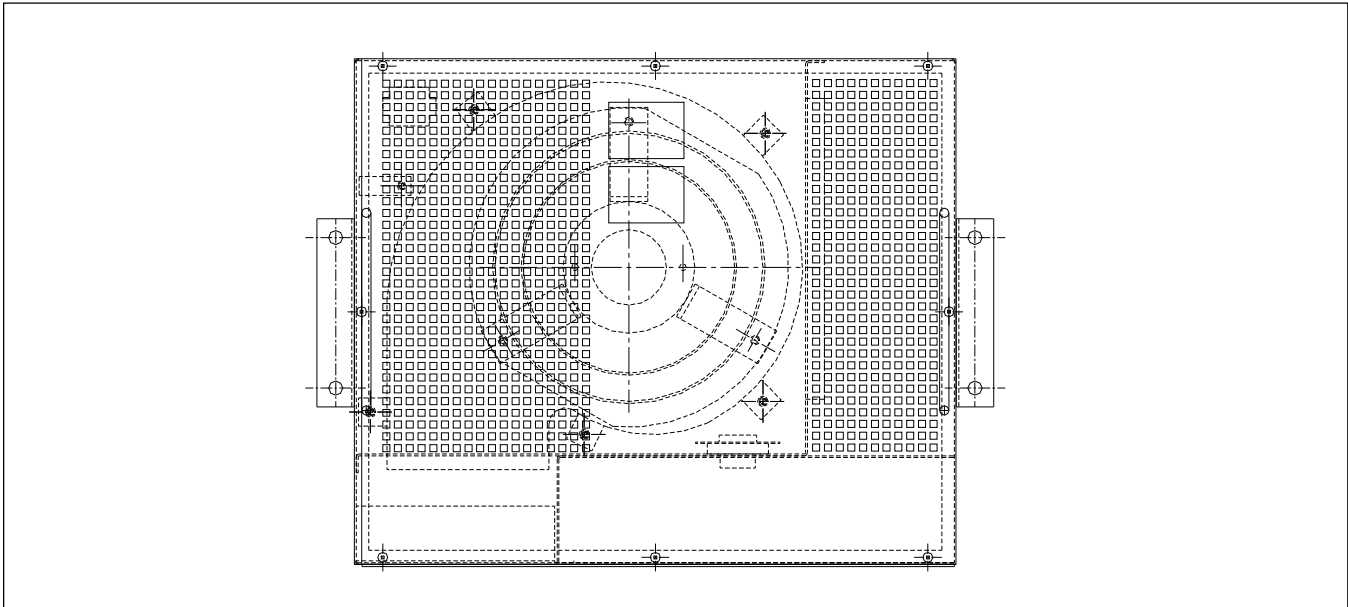

OWNER'S MANUAL



**RCH16225
Transit Duty Cab Heater**



This manual covers installation, maintenance, repair and replacement parts.

WARNING!
READ ALL IMPORTANT NOTICES ON PAGE 2.
PLEASE ADHERE TO INSTRUCTIONS PUBLISHED IN THIS MANUAL.
Failure to do so may be dangerous and may void certain provisions of your warranty.

Caloritech™ is a registered trademark of
CCI Thermal Technologies Inc.
Copyright © 1990. All rights reserved.

WARNING:

Disconnect heater from the power supply before opening enclosures, washing or servicing heater. This heater should only be serviced by qualified personnel with electrical heating equipment experience.

IMPORTANT NOTICES

WARNING:

Read and adhere to the following. Failure to do so may result in severe or fatal injury.

- 1. Read and follow all instructions in this manual.
- 2. Heater is not to be used in hazardous atmospheres where flammable vapors, gases, liquids or other combustible atmospheres are present.
- 3. Heater is to be connected and serviced only by a qualified electrician.
- 4. Installation and wiring of the heater must adhere to all applicable codes.
- 5. Before opening any enclosures, disconnect the heater from the power supply. Lock the switch in the "OFF" position and/or tag the switch to prevent unexpected power application.
- 6. The heater is not to be operated with the high-limit disconnected from the control circuit.
- 7. Elements get hot during operation. Contact can cause burns.
- 8. Use factory replacement parts only.
- 9. Maximum ambient operating temperature is 40°C(104°F).
- 10. If there are any questions or concerns regarding the heater, please refer to contact info on page 10.

*Photocopy
this page
for reuse.*

HEATER MAINTENANCE CHECKLIST

Heater Model : _____ Serial No. : _____

Date of Maintenance : _____ Maintenance Done By : _____

Comments : _____

ANNUALLY

1. CLEAN

- Calvane Elements Motor Fan
- Discharge Grill Inlet Grill

2. CHECK

- Motor for smooth, quiet operation

3. ELECTRICAL

- Check all terminal connections and conductors.**
Tighten loose connections. Conductors with damaged insulation must be replaced.

4. MECHANICAL

- Check motor shaft bearing play.** Replace motor if play is excessive, or if motor does not run quietly and smoothly. Bearings are permanently lubricated.
- Check fan.** Replace immediately if cracked or damaged.
- Check tightness of all hardware.** All fasteners must be tight.
- Turn heater on for a minimum of five minutes.** Check for warm air exiting heater through discharge grill.

INSTALLATION

The installation instructions provide a general guideline for the installation and wiring of the heater. All applicable codes must be adhered to.

MECHANICAL

Heaters must be installed as follows:

LOCATION

1. The heater's inlet and discharge areas must not be obstructed.
2. The air discharge is not to be directed at a thermostat.
3. The air discharge is directed across areas of heat loss.

MOUNTING

1. The mounting surface must be strong enough to:
 - a) support the heater's weight;
 - b) provide sufficient stiffness to prevent excessive vibration, and
 - c) withstand abusive situations such as transportable installations of the heater.

ELECTRICAL

WARNING:

Disconnect the power supply before installation of the heater. Lock the switch in the "OFF" (open) position and/or tag the switch to prevent unexpected power application. Installation and wiring of the heater must adhere to all applicable codes.

GENERAL

1. Use only copper conductors.
2. Supply voltage is to be within 10% of the data plate voltage.
3. External over-current protection is required and must meet data plate ratings for voltage, amperage and frequency.

FIELD WIRING

1. Heater is supplied with an enclosure that has mate-n-lock connector.
2. Heater requires external thermostat and controls. Thermostat and controls used with this heater must be:
 - a) listed for approved;
 - b) rated at 208 volt minimum and 5 amp minimum.

FINAL INSPECTION

1. Before application of electrical power:
 - a) check that all connections are secured and comply with the applicable code requirements;
 - b) confirm that the supply voltage is compatible with the data plate specifications;
 - c) remove any foreign objects from the heater;
 - d) ensure all external fittings and enclosure covers are secured;
 - e) ensure that the fan rotates freely.

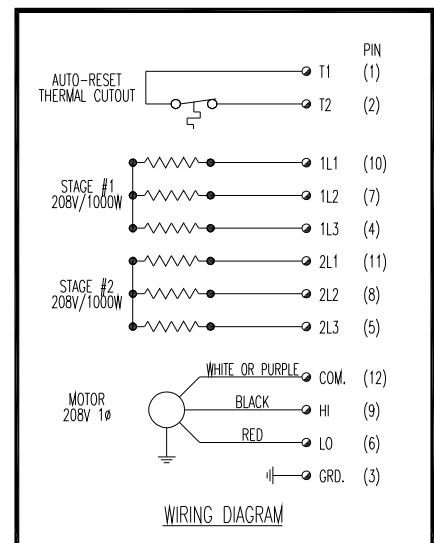

OPERATION

GENERAL

1. To operate heater, make sure power supply is properly connected as specified in the wiring schematic.
2. Ensure that the thermostat controlling the heater is set above the ambient temperature.
3. During normal operation, the high-limit control should not cycle the heater ON and OFF. If cycling occurs, check to see if there is an airflow blockage. If there are no obstructions, the heater must be examined by qualified personnel to determine the cause of the high-limit cycling.

REPAIR AND REPLACEMENT

WARNING:

Disconnect heater from the power supply before opening enclosures or servicing heater. Lock the switch in the "OFF" (open) position and/or tag the switch to prevent unexpected power application. This heater should only be serviced by qualified personnel with electrical heating equipment experience.

Note: ONLY USE FACTORY SUPPLIED REPLACEMENT PARTS OF THE SAME SPECIFICATION.

HEATING ELEMENTS

1. Remove discharge grill from heater. Disconnect all wires connected to the element terminals and remove all bus bars. Remove element brackets from heater.
2. Remove elements, noting their proper placement.
3. Install factory-supplied replacement elements. Ensure that the element brackets are in place and in good condition.
4. Reinstall all bus bars, wires, brackets, and discharge grill.

FAN

1. Remove grill from heater. Remove the screws securing the fan to the fan hub attached to the motor.
2. Replace fan with factory-supplied fan.

TEMPERATURE HIGH-LIMIT

1. Remove discharge grill from heater.
2. Remove the wires connected to the high-limit.
3. Remove the screws securing the high-limit.
4. Install factory-supplied high-limit.
5. Reinstall wires, high-limit screws and discharge grill.

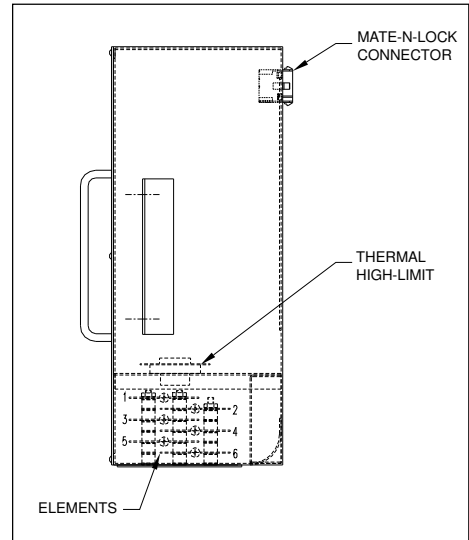
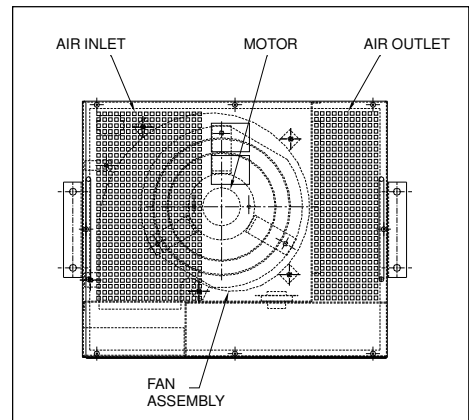

PARTS LIST

31	INSULATING SLEEVE 3/8" O.D. x 12" LG.		A15399-06	1
30	NYLON CABLE CLAMP 3/4"		A10687-133	1
29	PIN, CONNECTOR GROUND 14-18 AWG		770255-1	1
28	LABEL - CAUTION		C12390-02	1
27	LABEL - DANGER HIGH VOLTAGE		A11903-01	1
26	NAMEPLATE		C10090-94	1
25	PIN, CONNECTOR 14-18 AWG	AMP	770248-1	11
24	SCREW #10-32UNF x 1/4 LG.	304SS	A10683-71	12
23	HEX NUT #10-32UNF	Zn PL STEEL	A10685-03	6
22	LOCK WASHER #10, SPLIT	Zn PL STEEL	A10686-08	18
21	HEX NUT #8-32UNC	Zn PL STEEL	A10685-02	3
20	LOCK WASHER #8, SPLIT	Zn PL STEEL	A10686-05	3
19	MOTOR SUPPORT	PAINTED STEEL	40A132527G1	1
18	MOTOR		B16254-01	1
17	INLET RING		40A132754P3	1
16	BLOWER WHEEL		40A132754P2	1
15	HOUSING. BLOWER		40A132754P1	1
14	MATE-N-LOK II CONNECTOR, 12 PIN	AMP	770029-1	1
13	PUSH-ON CONNECTOR		PQ14R258B	2
12	RING CONNECTOR		YAV14	15
11	WIRE #14 AWG		SEW14B	12 FT.
10	HI-LIMIT, AUTO RESET 140°F		B11035-04	1
9	SCREW #8-32UNC x 1/2 LG.	Zn PL STEEL	A10682-02	20
8	COVER	#18 GA. ALUM.	B16251-01	1
7	HOUSING ASSEMBLY	#18 GA. ALUM.	D16248-01	1
6	LOCK WASHER #10, SPLIT	304SS	A10686-66	6
5	HEX NUT #10-32UNF	304SS	A10685-12	6
4	FLAT WASHER #10	304SS	A10686-27	50
3	INSULATOR, CERAMIC		161V349P43	34
2	ELEMENT MOUNTING BRACKET		B16250-01	1
1	CALVANE ELEMENT 120V/333W		FV16249-01	6
DET	DESCRIPTION		PART NO. NO. PIECE	QTY QTE

TEMPERATURE TEST RESULTS

CCI Thermal Catalogue No.	Heater Stage	Rated Volts	Phase	Rated Watts	Fan Speed	Approximate Airflow Rate	Ambient	Average Outlet Air Temp.	Approximate Temp. Rise
RCH16225-01	Stage 1	208	3	1000	Low	110 CFM	21°C 70°F	35°C 95°F	14C° 25F°
	Stage 2	208	3	2000	High	150 CFM	24°C 75°F	48°C 118°F	24C° 43F°

GENERAL SPECIFICATION

Heater Model:	RCH16225-01
Voltage:	208V
Power:	2000W
Phases/Connection:	3 / wye
Heating Element:	Transit duty calvane heaters
Protections:	High-limit, auto reset
Air Flow Control:	Variable, 2 speed fan
Front Cover:	Aluminum
Frame/enclosure:	Aluminum
Plug Connection:	Female Mate-N-Lock quick connector
Approx. Weight:	23 lbs.
Dimensions:	16"L x 13.5"H x 6.5"W (including handle)
Heater Drawing:	C16225 Rev. 7
Surface Front Grill:	304SS, 14GA
Grille Drawing:	B16252 Rev. 2

WARRANTY

CCI Thermal Technologies Inc. warrants to the purchaser of each new product that any part thereof which proves to be defective in material or workmanship under normal use within 18 months of the date of shipment or 12 months from the date of start of operation (whichever occurs first) will be repaired or replaced without charge. Any such defect should be brought to the attention of the company's office from which the product was purchased, which is authorized to furnish or replacement within the terms of this warranty.

The Company will not be responsible for any expenses incurred in installation, removal from service, transportation cost, or damages of any type whatsoever, including incidental or consequential damages. Some states or provinces do not allow exclusion or limitation of incidental or consequential damages so the preceding exclusion or limitation may not be applicable to you.

Since we cannot anticipate or control the condition under which our products may be used, we accept no responsibility for the safety and suitability of our products when used alone or in combination with other products. Tests for safety and suitability of the products should be done by the user.

This warranty will not apply if, in the judgement of the Company damage or failure has resulted from accident, alteration, misuse, abuse or operation on an incorrect power supply. The foregoing is in lieu of other warranties expressed or implied. CCI Thermal Technologies Inc. neither assumes nor authorizes any person to assume for it any other obligation, during transportation, installation and operation or liability in connection with the said product.

Since the paint finish may be damaged in use, no warranty applies to such paint finish except for manufacturing defects which become apparent within 30 days from date of installation.